

6,7 Kiln Line

, , , *
< >

1.

가 50%
가 1998

가

6,7 Kiln line 가 ,

6 7 Kiln line '90, 93 Polysius ,
1 7,600 ton - clinker .

6,7 Kiln P/H Air 175Hp Compressor Head ,
Air by - pass line Compressor shut down

Raw Mill E.P 1 Precollector Rapping System chain
air cylinder type cam tip chain

Cooler pusher coating manhole
가 , coating

2.

	Type	Specifications	Motor power (Kw)	
Raw Mill	V.R.M	6,100mm x 2,900mm	4,250	560T/Hr
Preheater	A.S.(C/C)	6 - Stage x 2 - String	1,700 x 2 (IDF)	7,600T/D
Kiln	Rotary	5.6m x 87m_L	720 x 2	
Cooler	Grate	3 Stage, 4.86m_W x 40.2m_L	450 x 2 (IDF)	
Coal Mill	V.R.M	2,700mm x 1,350mm	580	43T/Hr

3.

3.1. P/H Air Line

(1)

가. Compressor

		Motor	(Kg/cm ²)	Air (m ³ /min)		
#6K P/H	J175DS	175HP	14	16.0	Air cannon Cyclone aeration	1
	J175DS	175HP	14	16.0		1
	SC - 50	50HP	7	7.63	Precal simplex	1
	SC - 30	30HP	7	4.58	B/F dosing	1
	NH - 10	10HP	7	1.27	Silo	2
#7K P/H	J175DS	175HP	14	16.0	Air cannon Cyclone aeration	1
	J175DS	175HP	14	16.0		1
	J150DN	150HP	7	19.1	Precal simplex	1
	J75DN	75HP	7	9.8	B/F dosing	1

6 Kiln P/H

Compressor		(m ³ /min)	(m ³ /min)
175Hp	Air Cannon : 0.06m ³ /min × 40	2.4	18.6
	Cyclone Aeration : 0.5m ³ /min × 12	6	
50Hp	Precal Simplex B/F	5	
30Hp	Poldos B/F 2 Dosing B/F	2.2	
	Actuator, Air Cylinder	2	
10Hp	Silo	1	

7 Kiln P/H

Compressor		(m ³ /min)	(m ³ /min)
175Hp	Air Cannon : 0.06m ³ /min x 40	2.4	17.6
	Cyclone Aeration : 0.5m ³ /min x 12	6	
150Hp	Precal Simplex B/F	5	
75Hp	Poldos B/F 2 Dosing B/F	2.2	
	Actuator, Air Cylinder	2	

* 175Hp compressor : 14Kg/cm ² 1) : air cannon chute aeration 2) : 7Kg/cm ²	* 175Hp Head
* 175Hp compressor trouble - 2	* air 7Kg/cm ²
* Compressor Line - compressor 1 1 comp' air	* receiver tank by - pass line

6,7Kiln P/H Compressor room lay - out

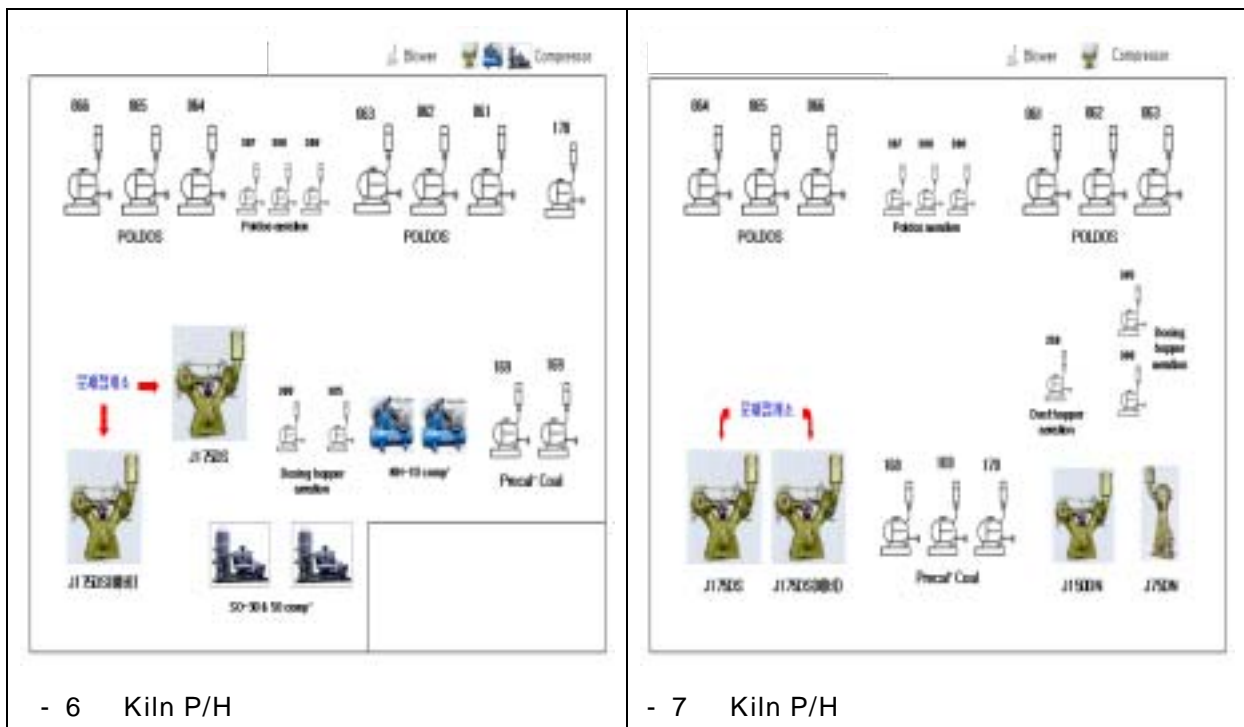

- 6 Kiln P/H







- 7 Kiln P/H

175Hp compressor overhaul (1998)

Line		Overhaul
#7K	1998. 04. 14 04. 24	Compressor /
#7K	1998. 05. 07	Head
#6K	1998. 09. 25 11. 01	Compressor /
#6K	1999. 09. 17 09. 21	Compressor /
#6K	1999. 11. 12	Head
#6K	2000. 05. 04	Head
#6K	2000. 10. 20 10. 30	Compressor /
* Valve	Air cooler	.

(2)

* 175Hp compressor Head			
-			
➤	Head : 14½"		
➤	Head : 5 7Kg/cm ²	7"	9¼"
➤	: compressor	manual	
* Head	.		
➤	Oil pump pressure setting : 3Kg/cm ²	Model	J 175 DS J 175 DN
➤	Discharge air pressure setting : 7Kg/cm ²	Motor	132Kw 132Kw
➤	Loading & unloading setting : 5Kg/cm ²		14Kg/cm ² 7Kg/cm ²
➤	7Kg/cm ² unloading 5Kg/cm ² loading		16m ³ /min 24m ³ /min
		Cylinder Size	14½" * 7" 14½" * 9¼"
* By - pass air line			
- 6	Kiln P/H line		
	50Hp & 30Hp comp'	line	175Hp comp' receiver tank 50A Pipe
- 7	Kiln P/h line		
	150Hp & 75Hp comp'	line	175Hp comp' line 150A Pipe

* 175Hp compressor Head			
			
: 175Hp compressor 7" Head		: 175Hp compressor 9 1/4" Head	
* Compressor By - pass line			
			
6 P/H By - Pass line		7 P/H By - Pass line	

(3)





가.

Compressor

➤ 175Hp Compressor

가 (150%)

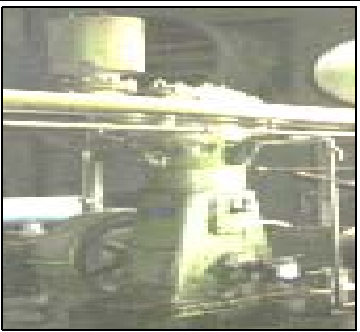
Compressor 가

6K			
	* 30Hp compressor	* 50Hp compressor	* 10Hp compressor 2
7K			
	* 75Hp compressor	* 150Hp compressor	

- line Kiln : air min kiln shut - down
-

3.2. Raw Mill E.P Rapping System

(1)

가. Mill E.P (Lodge Cottrell type)

	1	950,000 m ³ /H
Precollector Rapping Geared Motor	1	0.15Kw * 2.17RPM
Collector Rapping Gear (rph)	4	12rph,6rph,3rph,1rph
I.D.Fan	1	1,050,000 m ³ /H * 850mmAq
Motor	1	3,500Kw * 1180RPM

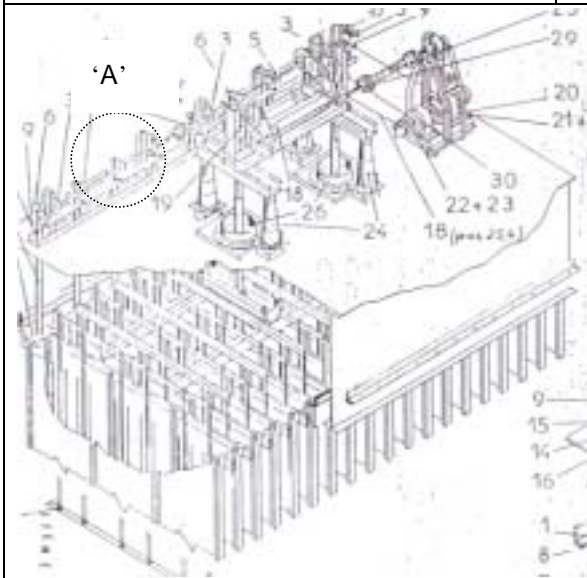

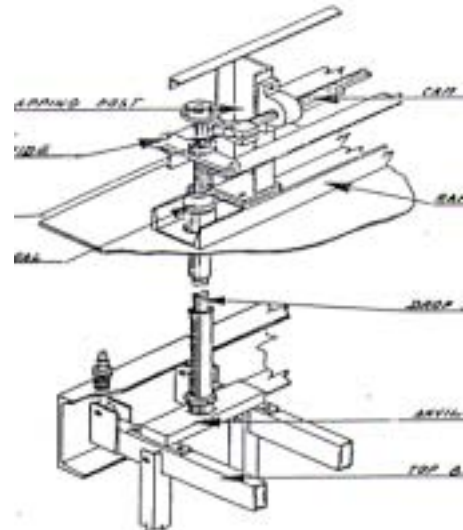

'A'

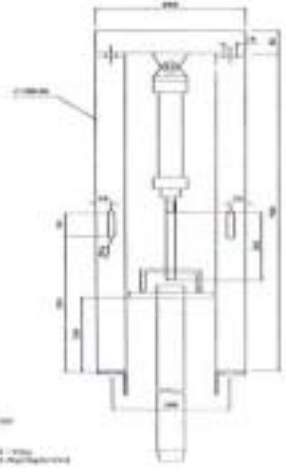
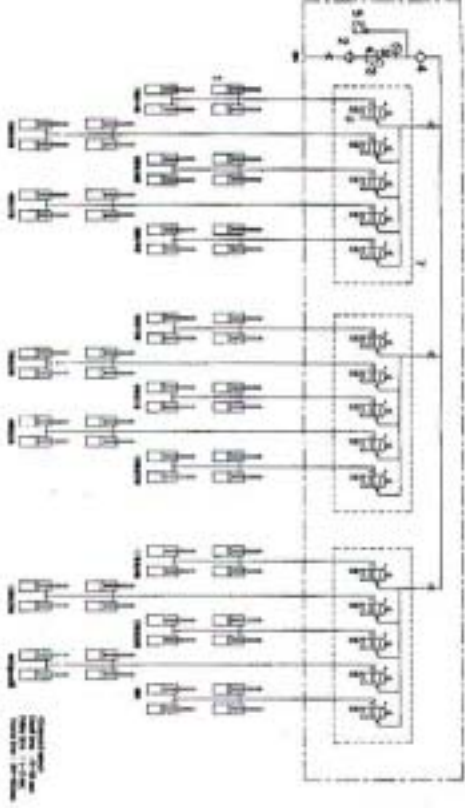

	<p>Trouble</p> <ul style="list-style-type: none"> * Chain error Rapping * Cam tip rapping bar Rapping * Cam tip rapping bar Guide 	<ul style="list-style-type: none"> - Rapping - Cam 100mm stroke

(2)

	<p>Rapping</p> <ul style="list-style-type: none"> - Chain & Cam type - Stroke : 100mm - stroke 150mm stroke
	<p>Air Unit</p> <ul style="list-style-type: none"> - Air cylinder : 52ea (5Kg/cm², 150mm stroke) - Air filter : 1ea - Air regulator : 1ea - Air lubricator : 1ea - Pressure switch : 1ea - Solenoid valve : 15ea - Mainfold Block : 3ea - Control box : 1set - valve : 52ea 

(3)

- : Air cylinder stroke
 - : Cam tip chain
 - Rapping control 가 : Cylinder air time 가
- Dust .

3.3 Cooler Coating (Pusher)

(1)

가. Cooler

Cooler	195.3m ² 4,864mm_W × 40,170mm_L, 13	1
I.D.F	12,500m ³ /min * 150mmAq, 450Kw, 12p	2
Hydraulic Drive	Pump (Cylinder)	3 (6)
Clinker crusher	1,450 × 4,914mm	1



1 Static grate type		
* 6K : 1990. 가 (Grate Plate Type) 1996. 1		* (Clinker)
* 7K : 1993. 가 (Grate Plate Type) 1997. 1		* Grate Plate Cooler



. Static cooler

* Cooler coating * Coating coating *	* Cooler coating pusher .

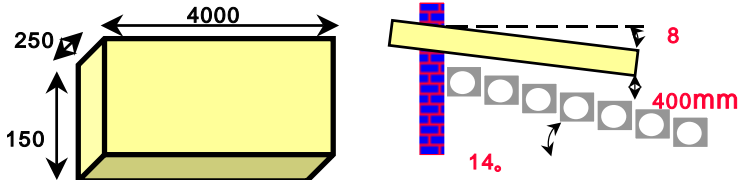
(2) Pusher

가.

item	
Pusher Dimension	
Hydraulic cylinder	<p>* : 50ton Piston :180mm</p> <p>* : 20ton Rod :150mm</p> <p>* $F = P \times A = 50.9\text{ton}$ ($200\text{Kg/cm}^2 \times (18\text{cm})^2 \times /4$)</p> 

<p>Pump</p>	<ul style="list-style-type: none"> * : 200Kg/cm² * : 30 * Pump Q = 200 /min Type = Vane pump 	
<p>Hydraulic Unit</p>	<ul style="list-style-type: none"> * valve * Stroke : Proximity Switch * : Relief valve * : Throttle valve 	

. Pusher

	6 line	7 line
	2000.07.10 18	2000. 08. 01 10
	2000. 07. 20	2000. 08 .12
	13	13
	100Kg/cm ²	100Kg/cm ²
Cylinder stroke	1,600mm	1,600mm

(3)

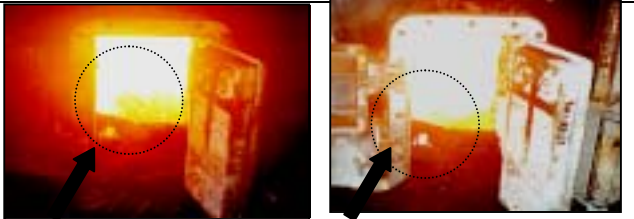
<ul style="list-style-type: none"> * - Kiln 	
<ul style="list-style-type: none"> * - Coating 	

